



For fracture mechanics studies, these COD gages are in compliance with standardized test methods, such as ASTM E1820 for determination of fracture toughness properties of metallic materials.



Model 3541 COD gage

The Model 3541 is designed for determination of fracture mechanics parameters such as JIC, KIC, R-curve, fatigue crack growth rate (da/dN), and testing to standards such as E1820, E399, E647, etc. These COD gages conform to the requirements of E1820 for JIC and R-curve determination. Special configurations are available to meet the requirements of ASTM E399 for fracture

toughness (*please consult the factory for these configurations*). In addition, the modified groove design complies with E1820 tests where greater stability and accuracy results from the sharper groove root. Clip-on gages are used for a variety of fracture mechanics tests, including compact tension, arc shaped, disk shaped, bend specimens or other specimen geometries in compliance with ASTM and other standards organization's test methods. Clip-on gages can be used directly on test specimens where the knife edges are integral with the test specimen or, alternately, with optional bolt-on knife edges mounted on the test specimen.

Model 3541 crack opening displacement gages are strain gaged devices, making them compatible with any electronics designed for strain gaged transducers. Most often they are connected to a test machine controller with electronics for a strain channel, and Epsilon will equip the extensometer with a compatible connector that is wired to plug directly into the controller. For systems lacking the required electronics, Epsilon can provide a variety of signal conditioning solutions that enable connecting to data acquisition systems or other equipment.

See the electronics section of this catalog for available signal conditioners and strain meters.



Model 3541 attached to bolt-on knife edges



Model 3541-012M-120M with 12 mm gauge length and +12 mm measuring range

Features

- **May be left on through specimen failure.**
- Full bridge, 350 ohm strain gaged design for compatibility with nearly any test system.
- Fully enclosed gages are protected from accidental damage.
- Sharp grooves per ASTM E1820, E813, and E399 for improved stability when mounted.
- For da/dN testing or pre-cracking, where maximum frequency (>50 Hz) is required, minimum measuring ranges are recommended.
- For KIC/JIC testing, maximum accuracy is achieved with the smallest measuring range and the largest gauge length that will perform the test.
- Maximum operating frequency may be from 5 Hz to >200 Hz depending on COD gage and test apparatus configurations.
- Includes the Epsilon Shunt Calibration System for on-site electrical calibration.
- Includes high quality foam lined case.

SPECIFICATIONS

Excitation: 5 to 10 VDC recommended, 12 VDC or VAC max.

Output: 2 to 4 mV/V nominal, depending on model

Accuracy Class: All standard configurations meet ASTM E1820, ISO 12135, and ISO 9513 Class 1 requirements for accuracy. A test certificate is included. Models that additionally meet ASTM E399 accuracy requirements are available in 2.5 and 4.0 mm (0.10 and 0.15 inch) measuring ranges. A test certificate for ASTM E399 is included with those models.

Linearity: $\leq 0.2\%$ of full scale measuring range

Temperature Range: Standard (-ST) is -40 °C to +100 °C (-40 °F to 210 °F)
Optional (-LHT) is -270 °C to +200 °C (-454 °F to 400 °F)

Cable: Integral, ultra-flexible cable, 2.5 m (8 ft) standard

Operating Force: 9 to 14 N (2 to 3 lbs), depending on model

OPTIONS

Connectors to interface to nearly any brand of test equipment
Available in special versions, including setups for narrow grips
Bolt-on knife edges (see p.104)



Special Model for Other Fracture Mechanics Testing

Special units are available for other fracture mechanics tests. For example, the photo to the right shows a gage for ASTM E1304, *Standard Test Method for Plane-Strain (Chevron-Notch) Fracture Toughness of Metallic Materials*.

This example was produced for a 1 inch diameter bar, with 0.4 inches of measuring range. Its performance, design, and accuracy is an enhancement of the design recommended in E1304.

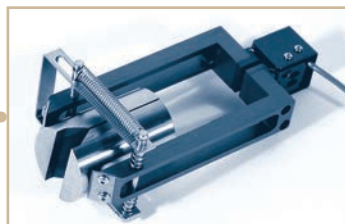

ORDERING INFORMATION

Model 3541 Available Versions: The following combinations of gauge length and measuring range listed below are available as standard, except as noted. All are available in any temperature range listed. *Other configurations may be available with special order; please contact Epsilon to discuss your requirements.*

Gauge Length		Measuring Range	
METRIC		METRIC	
-003M	3.0 mm	-025M ¹	+2.5 mm
-005M	5.0 mm	-040M ¹	+4.0 mm
-008M	8.0 mm	-070M	+7.0 mm
-010M	10.0 mm	-100M	+10.0 mm
-012M	12.0 mm	-120M	+12.0 mm
-020M	20.0 mm		
U.S.A.		U.S.A.	
-0010	0.100"	-100T ¹	+0.100"
-0020	0.200"	-150T ¹	+0.150"
-0030	0.300"	-200T ²	+0.200"
-0040	0.400"	-250T	+0.250"
-0047	0.475"	-500T	+0.500"
-0050	0.500"		

Model Number 3541-_____

Temperature Range	
-LT	-270 °C to 100 °C (-454 °F to 210 °F)
-ST	-40 °C to 100 °C (-40 °F to 210 °F)
-HT1	-40 °C to 150 °C (-40 °F to 300 °F)
-HT2	-40 °C to 200 °C (-40 °F to 400 °F)
-LHT	-270 °C to 200 °C (-454 °F to 400 °F)

¹ Available with special configuration to meet the requirements of ASTM E399 – inquire with Epsilon.

² Not available in 0.1 inch gauge length.

Example: 3541-010M-070M-LT: 10.0 mm gauge length, +7.0 mm measuring range, low temperature option (-270 °C to 100 °C)

See more COD gages at www.epsilontech.com
Contact us for your special testing requirements.

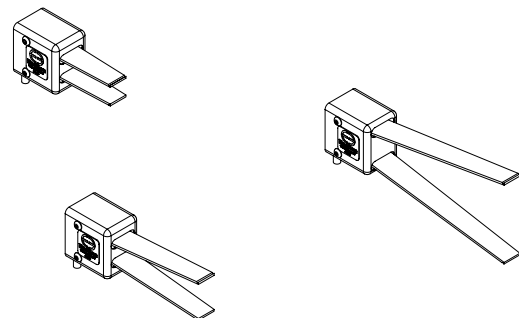

MODEL 3541 EXAMPLES