



General purpose extensometers for axial tensile, compression, and cyclic testing. Gauge lengths from 20 to 80 mm (and 0.8 to 2 inches) and full scale measuring ranges from 5% to 100% strain.



Model 3542 with 25 mm gauge length and $\pm 10\%$ measuring range

These extensometers are designed for testing a wide range of materials, including metals, plastics, composites and ceramics. All will perform both tension and compression strain measurement. The dual flexure design makes them very rugged and insensitive to vibrations, which permits higher frequency operation.

They come standard with Epsilon's quick attach kit, making it possible to mount the extensometer on the test specimen quickly and easily with one hand. The quick attach kit can be removed, allowing mounting of the extensometer with springs or rubber bands.

Model 3542 extensometers are strain gaged devices, making them compatible with any electronics designed for strain gaged transducers. Most often they are connected to a test machine controller with electronics for a strain channel, and Epsilon will equip the extensometer with a compatible connector wired to plug directly into the controller. For systems lacking the required electronics, Epsilon can provide a variety of solutions for signal conditioning and connection to data acquisition systems or other equipment.

For gauge lengths less than 20 mm (0.8 inches), Epsilon recommends the more compact Model 3442.

For gauge lengths 100 mm (4 inches) or greater, see Model 3542L.

See the electronics section of this catalog for available signal conditioners and strain meters.



Model 3542 with round metal specimen



Model 3542 Quick Attach feature enables mounting with one hand



Model 3542 configured for a very large specimen diameter

Extensometers for Composites Compression Testing

Models 3542 and 3442 extensometers can be furnished to clip directly onto composites compression fixtures, such as for ASTM D695. These use specially made wire forms for the test fixture. Contact Epsilon for details. Also see the Model 3442 miniature extensometer.

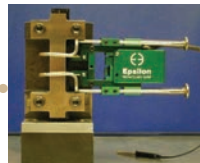

Model 3542 mounted on a D695 compression fixture for composite materials

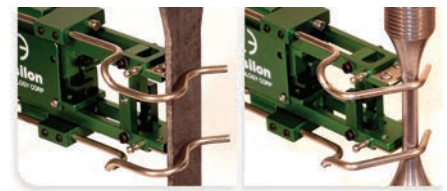

Standard quick attach wire forms included for round and flat samples

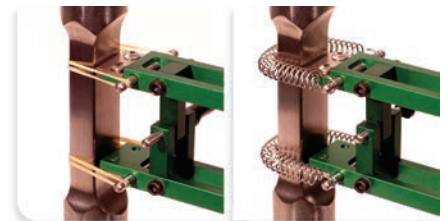

Rubber band and spring attachment options are included with Models 3542 and 3442

See the Model 3542 extensometer videos

Features

- **May be left on through specimen failure.**
- Full bridge, 350 ohm strain gaged design for compatibility with nearly any test system.
- Applicable for testing to:
 - ISO 6892-1, 527-2, 527-4, 527-5, 10113
 - ASTM E8, E9, D3039, D638, A370, D3552, E517, E646
- All models can measure in both tension and compression and can be used for cyclic testing.
- Standard quick attach kit allows one hand mounting to specimens.
- Rugged, dual flexure design for strength and improved performance. Much stronger than single flexure designs, this also allows cyclic testing at higher frequencies.
- All models have mechanical overtravel stops in both directions. Cable stops are used for overtravel protection where required. Epsilon's cable stops are fully contained between the arms of the extensometer and do not hang below where they can interfere with fixturing—especially during compression testing.
- Hardened tool steel knife edges are easily replaced. A spare set of standard knife edges and a set of 3-point knife edges come with every model 3542.
- Gauge length adapter kits enable configuration of multiple gauge lengths with one extensometer.
- Replaceable arms and spacers for ease of repair.
- High and low temperature options extend operation from as low as -270 °C to +200 °C (-454 °F to +400 °F).
- Includes the Epsilon Shunt Calibration System for on-site electrical calibration.
- Includes high quality foam lined case.

SPECIFICATIONS

<i>Excitation:</i>	5 to 10 VDC recommended, 12 VDC or VAC max.
<i>Output:</i>	2 to 4 mV/V, nominal, depending on model
<i>Accuracy:</i>	Standard configurations meet ASTM E83 class B-1 accuracy requirements for gauge lengths ≥ 20 mm and class B-2 for < 20 mm. All standard configurations meet ISO 9513 class 0,5. A test certificate is included.
<i>Linearity:</i>	$\leq 0.15\%$ of full scale measuring range
<i>Temperature Range:</i>	Standard (-ST) is -40 °C to +100 °C (-40 °F to 210 °F) Optional (-LHT) is -270 °C to +200 °C (-454 °F to 400 °F)
<i>Cable:</i>	Integral, ultra-flexible cable, 2.5 m (8 ft) standard
<i>Standard Quick Attach Kit:</i>	Wireforms are included for round samples 2-25 mm (0.08-1.0 inch) diameter and flats up to 12 mm thick by 31 mm wide (0.5 inch by 1.25 inch); wireforms are available for many other specimen sizes - contact Epsilon Rubber bands and springs for attachment are also included Model 3442 is recommended for specimen diameters < 2 mm
<i>Operating Force:</i>	Depends on model configuration; 10 to 100 g typical

OPTIONS

- Quick attach kit wire forms or cable attachment for large specimens
- Adapter kits to change gauge lengths
- Connectors to interface to nearly any brand of test equipment
- Special coatings and stainless steel knife edges available for biomedical tests
- Specialty knife edges (see page 106)



EPSILON TECH—Innovative designs and factory direct sales.

ORDERING INFORMATION

Model 3542 Available Versions: ANY combination of gauge length, measuring range and temperature range listed below is available, except as noted. *Other configurations may be available with special order; please contact Epsilon to discuss your requirements.*

Gauge Length	
METRIC	
-010M ¹	10.0 mm
-012M ¹	12.0 mm
-0125M ¹	12.5 mm
-020M	20.0 mm
-025M	25.0 mm
-030M	30.0 mm
-035M	35.0 mm
-040M	40.0 mm
-045M	45.0 mm
-050M	50.0 mm
-075M	75.0 mm
-080M	80.0 mm
U.S.A.	
-0050 ¹	0.500"
-0064 ¹	0.640"
-0100	1.000"
-0140	1.400"
-0200	2.000"

Measuring Range ²	
DESIGNATION	% STRAIN
-005 ³	$\pm 5\%$
-010	$\pm 10\%$
-020	+20%/-10%
-025	+25%/-10%
-050	+50%/-10%
-100	+100%/-10%

Model Number 3542- _____ - _____ - _____

Temperature Range	
-LT	-270 °C to 100 °C (-454 °F to 210 °F)
-ST	-40 °C to 100 °C (-40 °F to 210 °F)
-HT1	-40 °C to 150 °C (-40 °F to 300 °F)
-HT2	-40 °C to 200 °C (-40 °F to 400 °F)
-LHT	-270 °C to 200 °C (-454 °F to 400 °F)

¹ Epsilon recommends model 3442 for applications with gauge lengths < 20 mm (0.8 inches).
² Compressive ranges can be adjusted to higher values if required. Please contact Epsilon for your specific testing requirement.
³ Not available in 10 mm, 12.5 mm, or 0.50 inch gauge lengths.

Example: 3542-050M-025-LT: 50.0 mm gauge length, +25% / -10% measuring range, low temperature option (-270 °C to 100 °C)

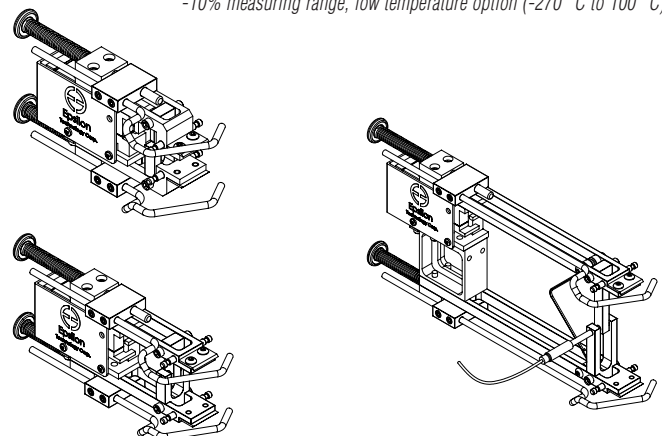

MODEL 3542 EXAMPLES